

Eclipse RatioMatic

Burners

Model RM0075

Version 5

Parameter	Specifications		
	Chamber Pressure "w.c. (mbar)	50 Hz	60 Hz
Blower Type			
Maximum Input, Btu/h (kW)¹	-2.0 (-5.0)	1,070,000 (313)	1,070,000 (313)
<i>For chamber pressures outside the given range or for varying chamber pressure conditions, contact Eclipse, Inc.</i>	-1.0 (-2.5)	990,000 (290)	990,000 (290)
	0.0 (0.0)	900,000 (263)	900,000 (263)
	1.0 (2.5)	800,000 (234)	800,000 (234)
	2.0 (5.0)	680,000 (199)	680,000 (199)
Minimum Input, Btu/h (kW)² <i>For lower inputs, contact Eclipse, Inc.</i>	with high turndown ratio regulator	30,000 (9)	
	with standard ratio regulator	40,000 (12)	
Main Gas Inlet Pressure, "w.c. (mbar)³ <i>Fuel pressure at ratio regulator inlet</i>	10 to 20 (25 to 50)		
High Fire Visible Flame Length, inches (mm) <i>Measured from the outlet end of the combustor</i>	Natural Gas	30 (762)	
	Propane / Butane	36 (914)	
Maximum Chamber Temperature, °F (°C)	Alloy Tube	1500 (815)	
	SiC Tube	1900 (1038)	
Flame Detection	Flame rod or UV Scanner		
Fuel⁴ <i>For any other mixed gas, contact Eclipse, Inc.</i>	Natural Gas, Propane, Butane		
Blower Motor Power, Hp (kW)		0.25 - 0.5 (0.18 - 0.37)	0.5 (0.37)
Weight, lbs (kg)⁵	88 (40)		
Approvals	 AM30		

¹ Maximum inputs for packaged blower versions are given for the standard combustion air blower without an inlet air filter.

² Turndown input based on neutral chamber conditions. Contact Eclipse for other chamber pressures.

³ For proper performance, this pressure must be kept constant across the burner operating range.

⁴ See Design Guide 110 for more information about typical fuel composition and properties.

⁵ All weights are approximate.

- All information is based on laboratory testing. Different chamber conditions will affect the data.
- All inputs based upon gross calorific values and standard conditions; 1 atmosphere, 70°F (21°C).
- Eclipse reserves the right to change the construction and/or configuration of our products at any time without being obliged to adjust earlier supplies accordingly.

Performance Graphs

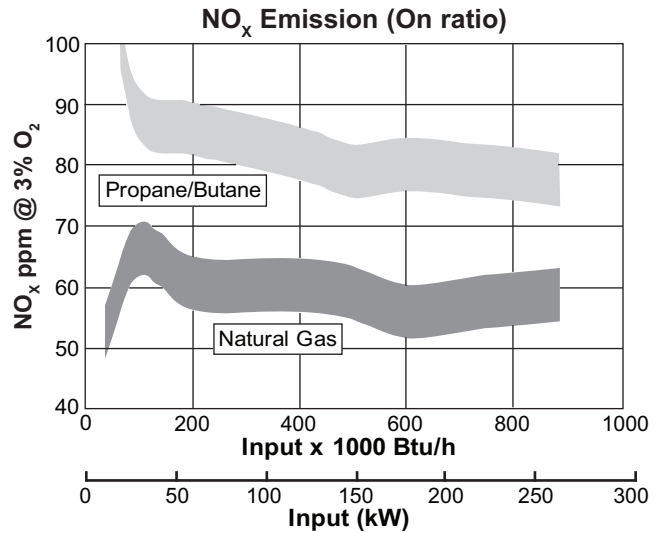
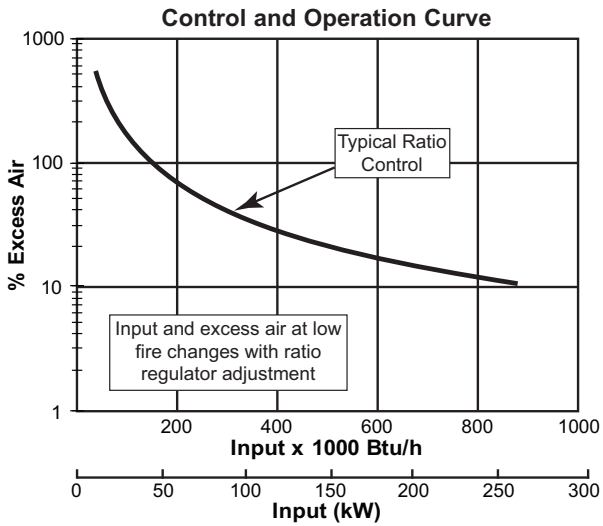

NO_x Emission data is given for:

- Ambient combustion air ~70°F (21°C)
- Less than 700°F (370°C) firing chamber
- Minimal process air velocity
- Low fire input adjusted to 20,000 Btu/h (6 kW)
- ppm volume, dry @ 3% O₂
- Neutral chamber pressure

Emissions from the burner are influenced by:

- Chamber conditions
- Fuel type
- Firing rate
- Ratio regulator adjustment
- Combustion air temperature

CO emission is largely influenced by chamber conditions. Contact your local Eclipse representative for an estimate of CO emission on your application.

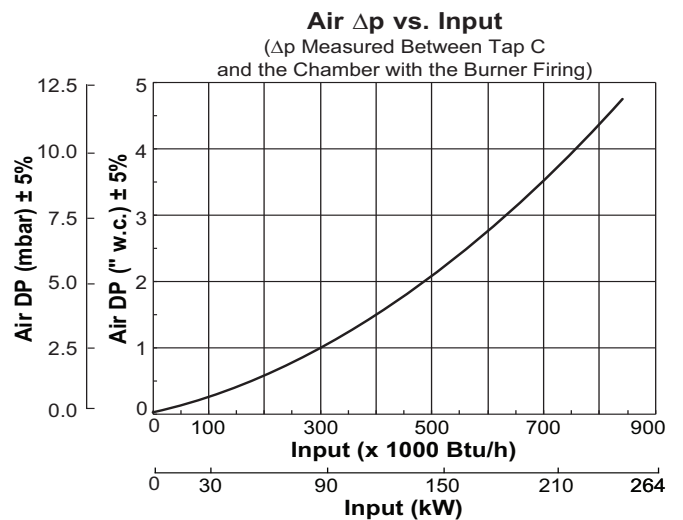
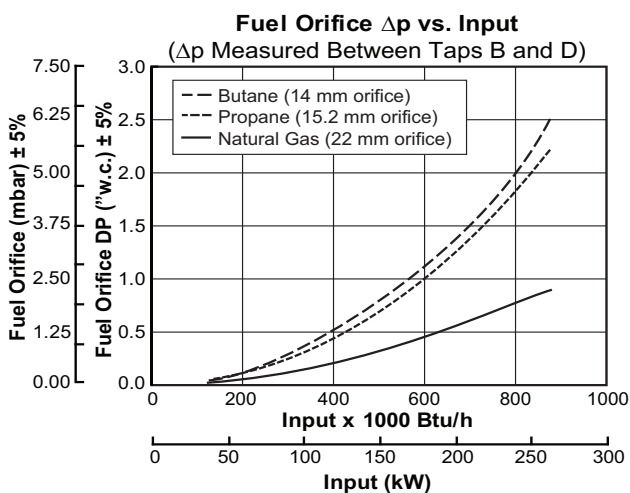

Dimensions and Specifications

Dimensions in mm (inches)

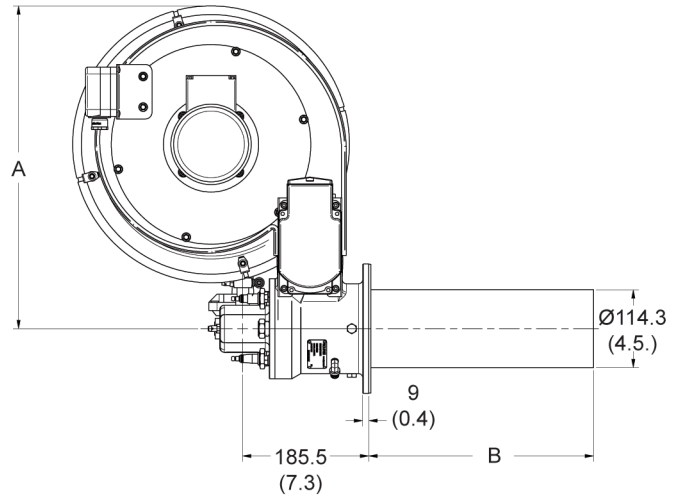
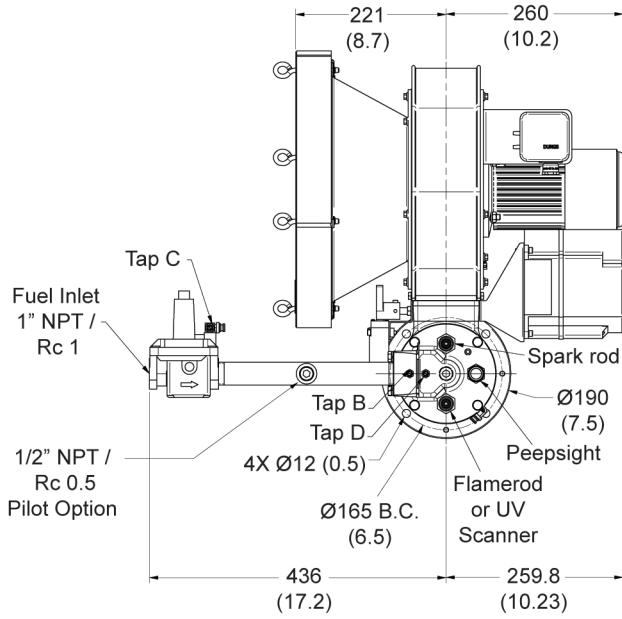

Blower Size	A
50 Hz	474 (18.7)
60 Hz	429 (16.9)

Combustor Type	B
Straight Stainless Steel Alloy Tube	254 (10)
Straight Stainless Steel Alloy/Silicon Carbide Tube	330 (13)
Straight Stainless Steel Alloy Tube	406 (16)

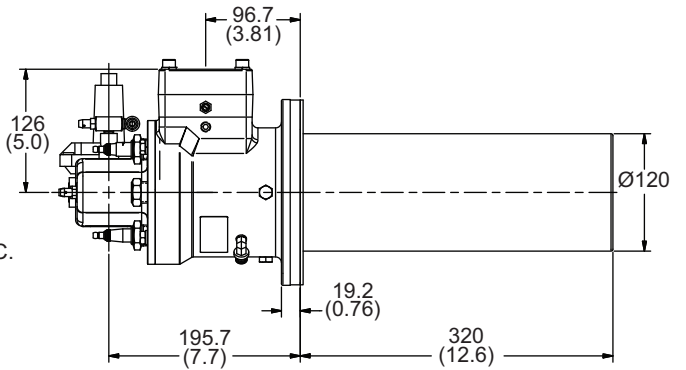
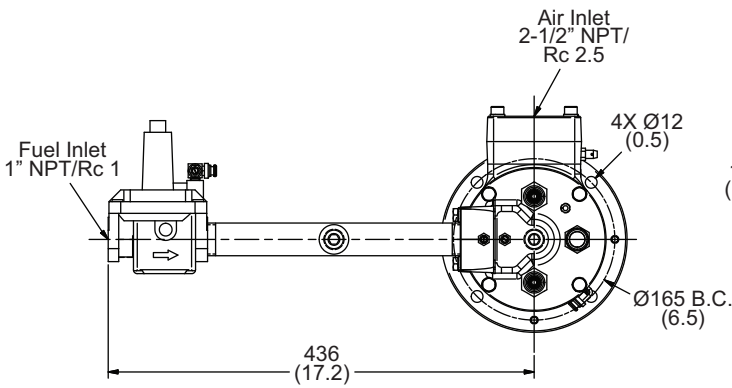

Shown with Silicon Carbide Combustor and Flange

Combustor Options

Alloy Combustor

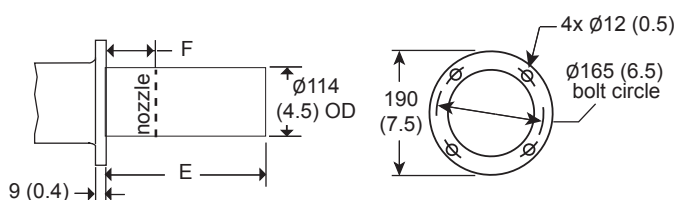

Silicon Carbide Combustor

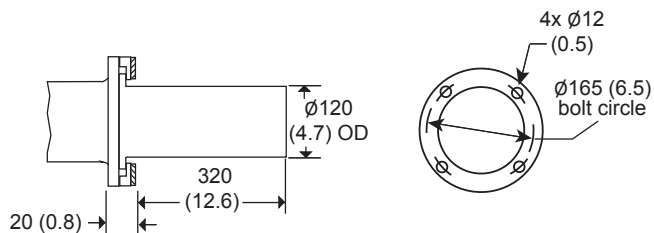

E	F
254 (10.0)	84 (3.3)
330 (13.0)	160 (6.3)
406 (16.0)	236 (9.3)

Burner Configurations

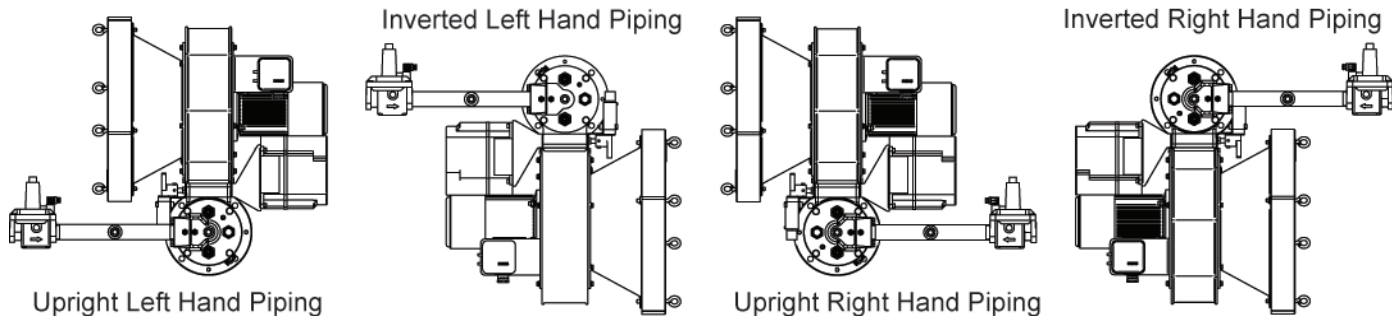

Even though the blower motor is on the "left" side of the inverted units, it is still a "right hand" motor in relationship to the blower assembly.

Offered By:



Power Equipment Company
 2011 Williamsburg Road Richmond, Virginia 23231
 Tel: 804-236-3800 Fax: 804-236-3882 www.peconet.com